

# EHM12-3F

3 Channels magnetic incremental encoder

Special Specification

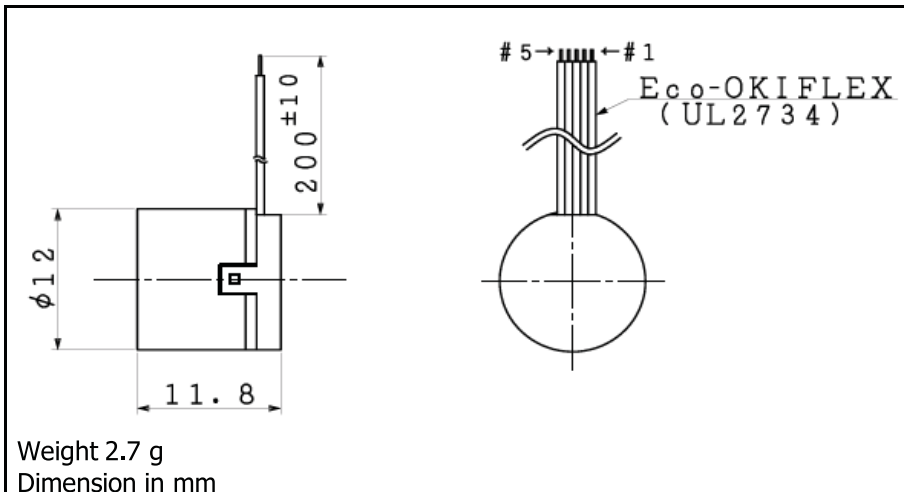

### Output circuit

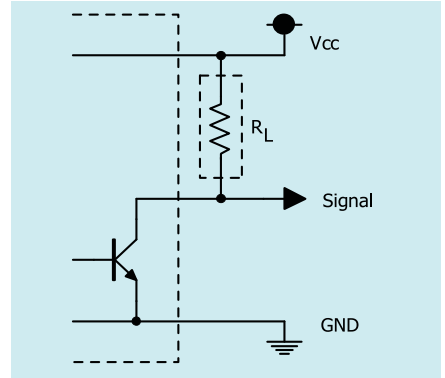

Recommended pull-up resistor  
 $R_L = 2.7 \text{ k}\Omega$

For combination with motors : CGE16, CGR16 Series

### Specifications at 25 °C

	EHM12-3F	
1 Sensor	Hall IC	
2 Encoder Type	Incremental	
3 Output Signal	Open collector	
4 Number of Channels	3	channel
5 Resolution (Max. speed = 17,000 rpm)	1024	pulse/rev
6 Max. Frequency Response	500	kHz
7 Supply Voltage, Vcc	4.5 . . . 5.5	V
8 Supply Current, typical	21	mA
9 Output Voltage "H"	$\geq 4.0$ (Max. Vcc)	V
10 Output Voltage "L"	$\leq 0.6$	V
11 Output current per channel	30	mA
12 Rise and fall time ( $R_L = 2.7 \text{ k}\Omega$ and $C_L = 25 \text{ pF}$ ), typical	$T_r = 200, T_f = 50$	ns
13 Inertia	4.25	$\text{gmm}^2$
14 Operating Temperature	-25 . . . +85	°C
15 Storage Temperature	-40 . . . +85	°C

### Wave form (for motor shaft clockwise rotation)

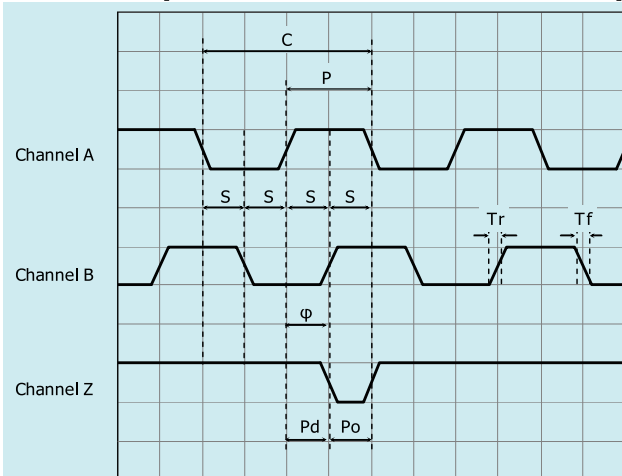

### Output signal information

Cycle C	360±61	°e
Pulse P	180±61	°e
A to B channel phase shift, $\phi$	90±61	°e
Logic state width, S	90±61	°e
Z channel width, $P_o$	90±61	°e
A to Z channel phase shift, $P_d$	90±61	°e

※Maximal error ( $\pm e$ ) indicated above.

### Electrical connections

#1 (Green)	Ch.A
#2	Ch.B
#3	Ch.Z
#4	Vcc
#5	GND

V01

Specifications subject to change without notice